



Longevity Arbor

PLEASE READ COMPLETELY BEFORE YOU BEGIN ASSEMBLY

CHECK BOX FOR THESE CONTENTS

- 1** Trellis Caps (16)
- 2** Headers (2)
- 3** Braces (4)
- 4** Lattice Side Panels (2)

HARDWARE

- 1" Wood screws (32)
- 2" Wood screws (16)
- 2 1/2" Wood screws (8)
- Anchoring kit.
- Brass medallion and nails (2)

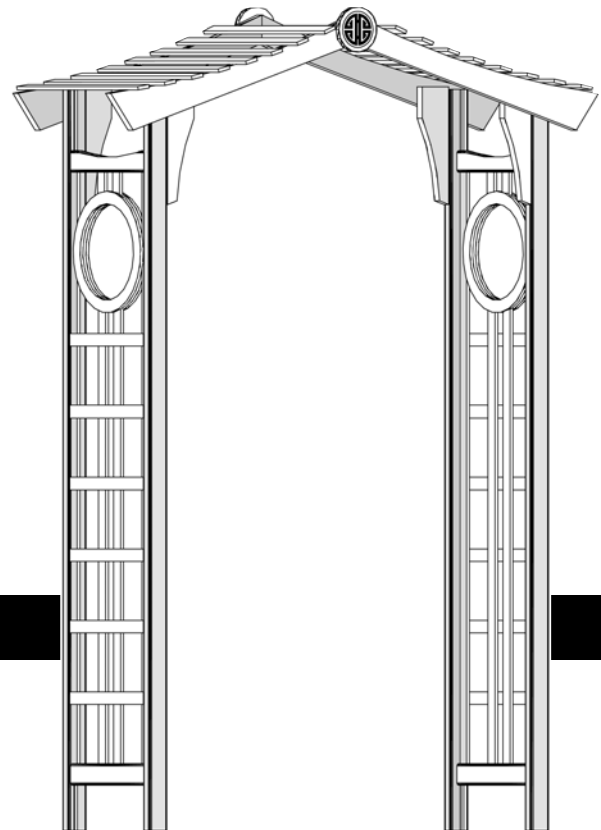

TOOLS YOU WILL NEED

- Phillips screwdriver (electric driver recommended)
- Small hammer
- Two bags of concrete mix (60#) to anchor the arbor

HANDY TO HAVE

- Tape measure
- Needle nose pliers

PRELIMINARIES

ARBOR PAINTING:

If you wish to stain or paint your arbor, we recommend that you do so before assembly, it makes the job easier. Be careful not to cover up guide marks on top of headers

WORK AREA

Select an area close to where the arbor will be finally placed. While the assembled unit is not very heavy, it is awkward to move far and requires two people to do so easily.

The assembly area should be relatively flat and open, at least 8'x6'. A lawn, driveway or wide path will be satisfactory.

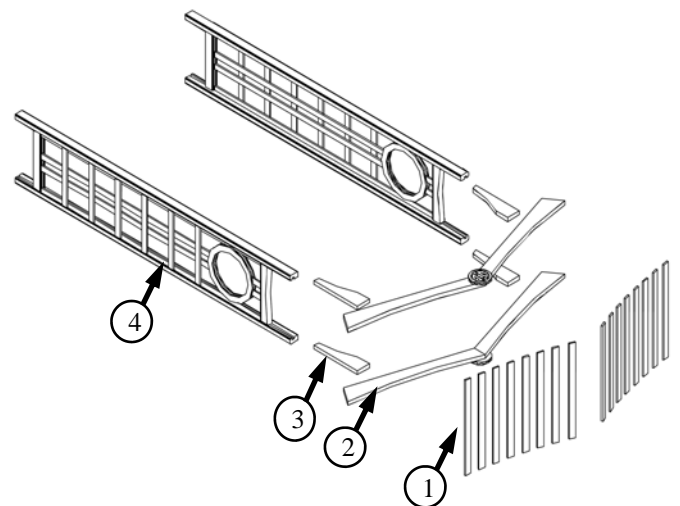

CONNECTING THE MEDALLIONS TO THE HEADERS

STEP 1

We recommend installing the medallion on the header prior to final assembly. Needle nose pliers can be helpful in holding the 1/2" nail.

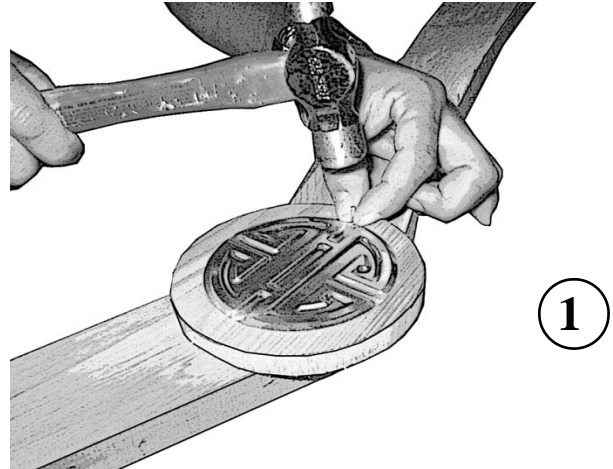

CONNECTING THE BRACES TO THE HEADER

STEP 2

Install all 4 braces on the ends of the headers into the pre-drilled holes using 2" screws.

Important note:

Placing screws into pre-drilled holes ensures proper alignment of side panels.

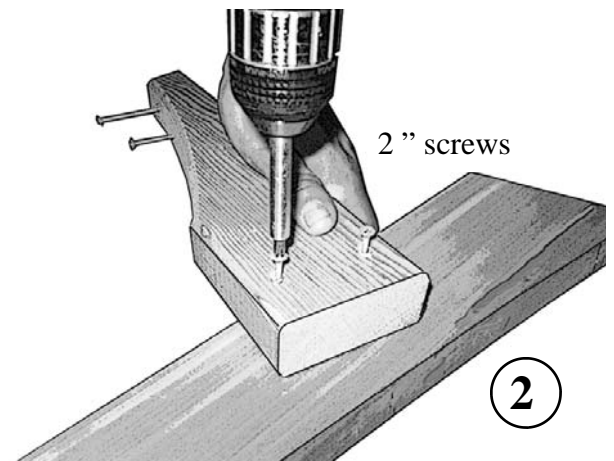

CONNECTING THE SIDE PANEL TO THE HEADERS

STEP 3

Line up the top of the brace and the top of the side panel. Position the side panel against the back of the brace. Connect the side panel to the header using the 2" wood screws. Connect the brace to the side panel using 2 1/2" wood screws. Repeat on both ends of the header.

Important note:

When positioning side panel for attachment to header make sure the staples in side panel lattice face to the **outside** of arbor.

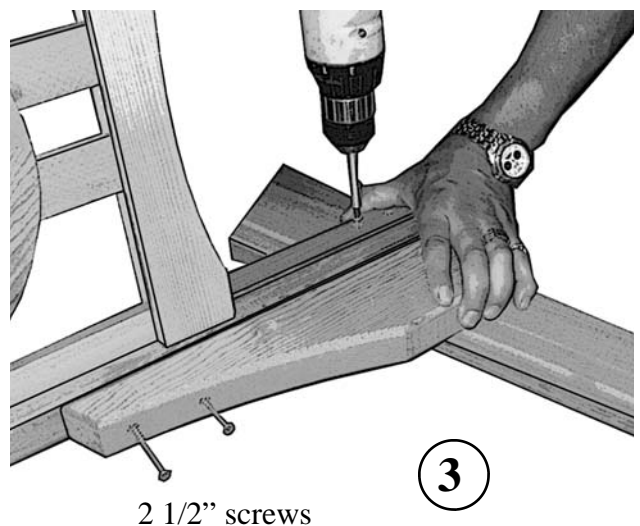

TURNING THE ARBOR 180 DEGREES TO ATTACH SECOND HEADER

STEP 4

After attaching the first header to the side panels,

Turn the assembly over by lifting the sides and moving backward. Then, turn and lower the arbor over the second header.

Attach the second header following the same method as the first header.

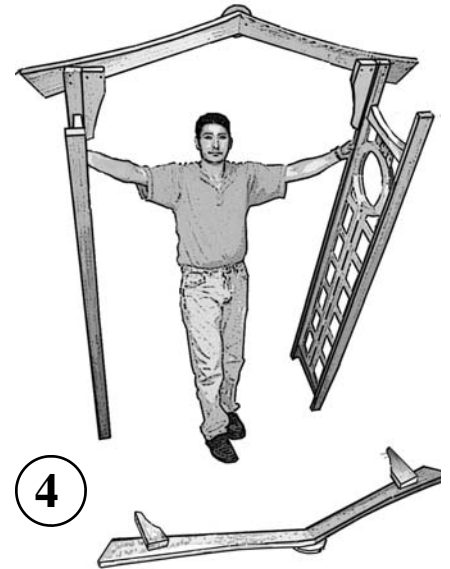

BLOCKING

STEP 5

Support the arbor with a block or other item to allow clearance for the attachment of the trellis caps.

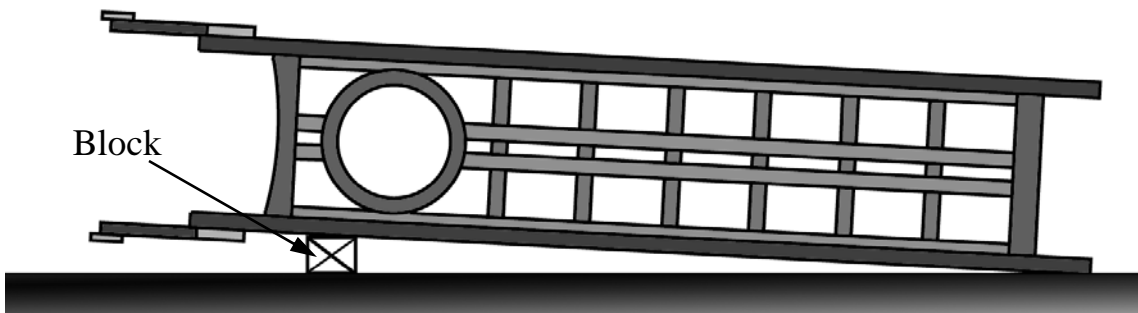

ATTACH THE CAPS TO THE HEADERS

STEP 6

Install the top caps on both side of the medallion using 1" screws in the locating holes.

Use the supplied 2" spacer to install the rest of the caps.

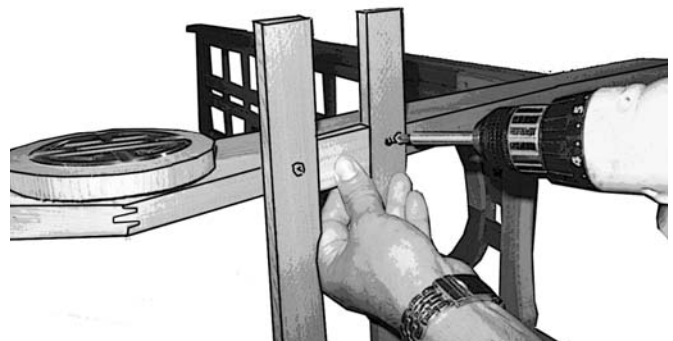
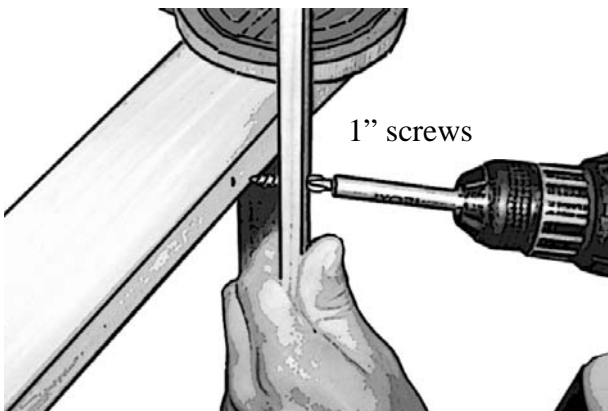

INSTALLING THE ARBOR

Arbors must be well secured to prevent tipping over. We have provided 4 anchors for securing the arbor to concrete footings, the most common method of securing it. If you use this method you will also need 2 bags of pre-mix concrete. In some cases it may be acceptable to secure the arbor to some existing structure such as a fence post. If you are installing your arbor on concrete or a deck, see your hardware dealer for appropriate hardware.

- A. Move the arbor to its final location. (You'll need a helper). When you are satisfied with the location, mark the positions of the posts, then move the arbor aside and lay it carefully on its side. Dig a hole at least 6" wide and 12" deep for each post.
- B. Attach the anchors to the posts using the 3/4" screws provided. See **diagram 1**.
- C. Carefully, move the arbor back to its final position. Support it plumb and level over the holes with bricks, stones or blocks of wood under the side panel rails. The post bottoms should be close to the level of the ground surface. See **diagram 2**.
- D. Fill each hole with bagged concrete, mixed according to the manufacturer's instructions. Concrete should come to within 1/4" of the bottom of the posts but the post should not be in the concrete.

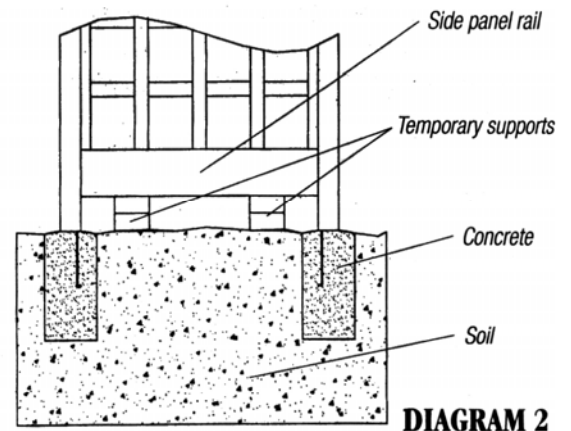
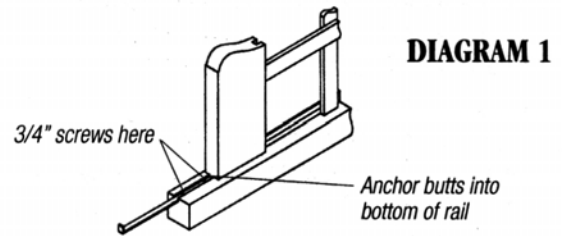

Fine Garden Structures

LWO Corporation
3841 N. Columbia Blvd.
Portland, Oregon 97217
(503) 286-5372
(800) 459-8718

www.arboria.com